

BIG SANDY RURAL ELECTRIC *Cooperative Corporation*

www.bigsandyrecc.com

504 Eleventh Street
Paintsville, KY 41240
(606) 789-4095
(888) 789-7322
7:30 a.m. to 4:30 p.m.



DAVID ESTEPP
BIG SANDY RECC
MANAGER

Big Sandy RECC has monthly electric bills too

When you look at your monthly electric bill from Big Sandy RECC, you might wonder sometimes where your money's going.

At Big Sandy RECC, we work diligently to keep your power costs as low as we can. That's part of our mission. Big Sandy RECC is a not-for-profit cooperative owned by you, our members, and we exist for the very purpose of serving you as affordably and efficiently as possible.

You may be surprised to know that out of every dollar of revenue we collect, 94 cents goes for our own expenses. It costs 73 cents of that dollar for Big Sandy RECC to buy electricity from our wholesale power supplier, East Kentucky Power Cooperative. So just like you, we have an electric bill, and our bill to East Kentucky Power is several million dollars each month.

We spend another 21 cents of each dollar on interest, depreciation, operations, maintenance, and other unavoidable costs of doing business.

Typically, our margin—the money left over from our revenue after our expenses are paid—is only about 6 cents on every dollar we receive. We use that 6 percent as reserve capital to cover business risks like storm damage and uncollected bills.

East Kentucky Power is also a

not-for-profit company. In fact, Big Sandy RECC and 15 other rural Kentucky cooperatives together co-own East Kentucky Power, which generates your power from plants in Mason, Pulaski, and Clark counties and then transmits it to us.

Because East Kentucky Power shares our purpose, it likewise operates on very low financial margins—about 4 percent, with 96 percent of its revenue going to fixed expenses like coal and the cost of operating and maintaining the electric system.

Combined, Big Sandy RECC, our 15 sister cooperatives, and East Kentucky Power form a not-for-profit system that serves 1 million Kentucky customers. This system was organized many years ago to provide electricity to farms and sparsely populated rural communities rather than to cities or factories. We all still believe in that mission.

Our goal is always to provide you with affordable, reliable power at the lowest possible cost.

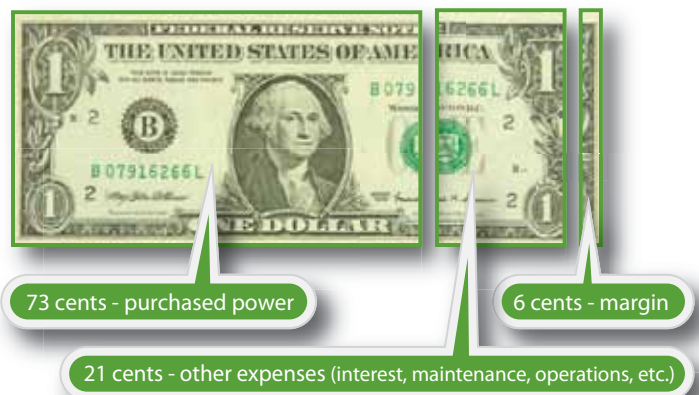

Why you should consider having a home energy evaluation

A free energy evaluation by Big Sandy RECC can measure how much energy your home consumes and show you how to make your house more energy efficient. The evaluation will point out problems that may, when corrected, save you significant money.

An evaluation works like this. If you have a home that's heated by electricity, our energy advisor will inspect it and document its energy characteristics. The advisor will look at insulation, various appliances, windows, heating and cooling systems, and water heaters. The advisor likely

will conduct diagnostic exams such as a blower door test, which measures air leaks in the building.

From this process, the advisor can recommend appropriate energy-conserving changes. All this advice is totally free.

Many of the recommended energy-saving upgrades will pay for themselves over time by decreasing your monthly electric bills.

Beyond the financial savings, home energy improvements can also raise the comfort level in your home. Imagine your house without the draftiness or the cold basement.

Finally, making your home more energy efficient might increase its value. According to one study, the market value of a house can increase \$20 for every \$1 decrease in annual energy costs.

Once the inspection is completed and you've received your report, you'll have to actually undertake the recommended improvements if you want to reap any of the benefits.

If you're interested in a free home energy evaluation, contact us at (606) 789-4095 and set up an appointment. We'll take it from there.

Yes—it's really that simple!



NOVEMBER 2011 DEALS

Your Co-op Connections Card

The Co-op Connections Card puts you in touch with savings at more than 20,000 businesses nationally and provides savings of up to 60 percent on prescriptions. Go to www.connections.coop for more information. Here are other savings you can get:

• **Advance Auto Parts** – Get \$50 off all orders over \$200 (use code BIG50 at checkout).

• **Cooperative Healthy Savings** – Cooperative Healthy Savings provides discounts on dental, vision, and hearing services. The \$4.25 monthly fee

is \$1.25 off the regular fee and provides discounts to your family. Go to www.cooperativehealthysavings.com and enter the group number from the back of your Co-op Connections Card.

• **Howard Johnson**

– Whether you are on the road for business or pleasure, Howard Johnson has a room for you. For Co-op Connections Card members, that room

is available at an additional 20 percent off the “Best Available Rate” at participating locations. Call (877) 670-7088.



bigsandyrecc.com

PAY MY BILL

START MY SERVICE

STOP MY SERVICE

REPORT MY OUTAGE

STORM HQ



Notice to Big Sandy RECC Members

Beginning November 2011, Big Sandy RECC will be adjusting their meter read date to the first of each month. As a result your November 1st billing will reflect 6 extra days.

BOARD OF DIRECTORS

Wade May
Chairman

Danny Wallen
Vice Chairman

Kelly Shepherd
Secretary-Treasurer

Bill Maxey
Greg Davis
Robert Moore

Attorney
A.A. Burchett

EMERGENCIES/ OUTAGES

(Nights, Weekends & Holidays)

Toll Free (888) 789-7322

learn the

LINGO

What is an outage?

An outage is the interruption of service to an electric customer due to malfunctioning power plants, transmission lines, substations or distribution equipment.

Simple Savings

easy energy tips: Fix duct leakage

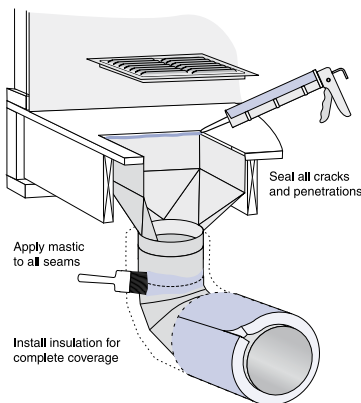

No matter where we turn these days, bills are going up. Your cooperative is also being squeezed by increasing costs.

In a co-op, though, we're in this together. Here's a tip that helps keep costs down for you and your co-op when you use less electricity.

One simple step is to fix the leakage in your ductwork. Most ducts leak 30 percent of a home's heating and cooling. To fix that, simply apply a substance called mastic with a paintbrush to every duct seam. By plugging these leaks, you'll go a long way toward saving some **green**.